

**Flexy Compact  
 Ambient Unit on cupboard (3 GN) with  
 wheels and two stainless steel tray  
 sliders, H=750mm**

ITEM # \_\_\_\_\_

MODEL # \_\_\_\_\_

NAME # \_\_\_\_\_

SIS # \_\_\_\_\_

AIA # \_\_\_\_\_

**322071 (F00N3KW00S)**

 Ambient Unit on cupboard  
 (3 GN) with wheels and two  
 stainless steel tray sliders,  
 H=750mm

### Short Form Specification

Item No. \_\_\_\_\_

Compact design, ideal for space saving environments. AISI 304 Foldable tray sliders on long sides. Unit mounted on 125 mm wheels 2 swivel and 2 with brakes. Top provides ample displaying or workspace surface. Soft closing doors on operator side. Underneath ambient cupboard with doors. Sturdy body construction with laminated panelings on 4 sides. 750mm worktop height.

### Main Features

- Perfect compact design makes it ideal for space saving environments.
- CB and CE certified by a third party notified body.
- Soft closing doors on operator side.
- Available options with online configurator: colors, tray sliders, overshelves, feet/wheels with desired diameter, height 750mm for kids.
- Top provides ample displaying or workspace surface.
- Optional plinth can be installed to cover the feet or the wheels.
- AISI 304 Tray slider in flush mounted stainless steel is installed on long sides and they can also be folded down to facilitate passage of the units through doorways.
- Ideal for servery lines without an operator.
- Unit mounted on 125 mm wheels 2 swivel and 2 with brakes.
- Food introduced at the correct temperature maintains its core temperature according to Afnor Standards.
- Available dimensions: 1, 2, 3, 4 GN.
- Thanks to the sleek, minimalist glass structure, food and dust does not get trapped and the cleaning is made easier.

### Construction

- Top in AISI 304.
- Sturdy construction with laminated panelings on 4 sides.

APPROVAL: \_\_\_\_\_

Front

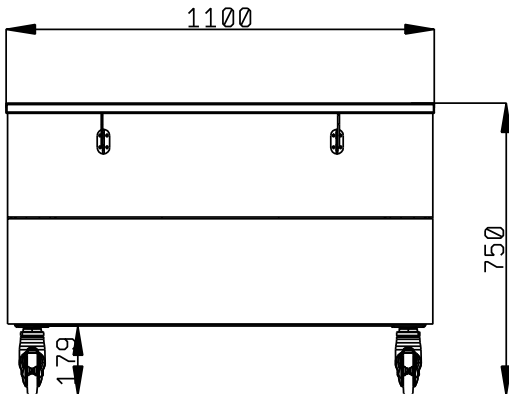

Side

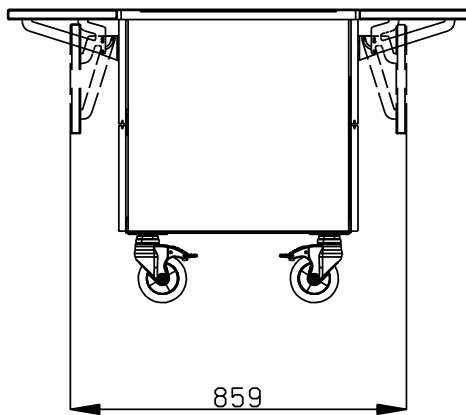

Top

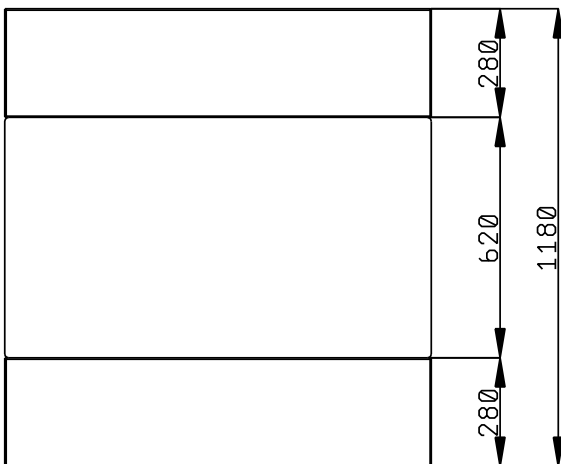
**Key Information:**

N° of doors:	2
322071 (F00N3KW00S)	
External dimensions, Width:	1100 mm
External dimensions, Depth:	1180 mm
External dimensions, Height:	750 mm
Net weight:	83 kg
Shipping height:	780 mm
Shipping width:	899 mm
Shipping depth:	1140 mm
Shipping volume:	0.8 m <sup>3</sup>